

05/18/2026 02:18 OWNERSHIP 619017000	PROPERTY DESCRIPTION	TAX DESCRIPTION	MAP NUMBER	CARD#
OFFNER JOSHUA JAMES OFFNER JANELLE JULIANNE 549 SNEAKING CREEK DR HAYESVILLE, NC 28904 DEED: 00446 0130 11/18/2020 \$244,500	LOT B  PLATBOOK/PAGE/DATE: NB: 00214 RHINEHRDT SUBDIVISION 549 SNEAKING CR DR	HIAWASSEE HAYESVILLE FIRE DISTRICT	547800457118 RECORD NUMBER: 7484 ROUTE: 547800 064 LISTER: TOM HYDER 1/1/2026 REVIEWER: TOM HYDER 1/13/2025 2:58:00 PM	1 / 1

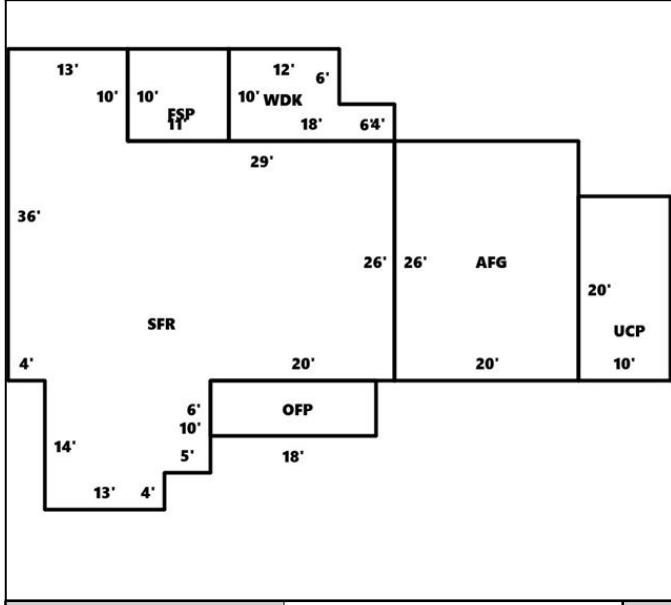

TOPO	STREET	UTILITIES	NOTES	LT				
			LAKE VIEW	0.0000				
#	LAND CLASS	SIZE	BASERATE	* ACF	* ADJ	= ADJ RATE	* UNITS	= LNDVALUE
1	50RESIDENTIAL	1.000	100000	1.00	1.25	125000	1.000	125000
ACREAGE FACTOR:		FRONTAGE FACTOR:		LAND VALUE		125,000		
#	OTHER FEATURES	SIZE	BASERATE	COND	ADJ RATE	UNITS	VALUE	
OTHER FEATURES VALUE:								0
FOUNDATION		XTR_FINISH	ROOF TYPE		ROOF MTRL		SIZE/QTY	
5 CONCRETE		07 ALUMINUM/VINYL	02 GABLE		01 ASPHALT		1.0000 STHT 3 BDRM	
WALL FINISH		FLOORS	HEAT&AIR		HEAT FUEL		BUILDING #	
01 DRYWALL		05 CARPET 10 VINYL	01 FORCED HOT AIR 11 CENTRAL AIR CONDI		03 GAS		1	

<b>IMPROVEMENT TYPE:</b> SINGLE FAMILY	GRADE: B	AYB: 1996	EYB: 1996	CONDITION: Good	DEPR TABLE:	SQ FT TABLE:
--	----------	-----------	-----------	-----------------	-------------	--------------

<b>DIMENSIONS:</b> SFR-CL40U30R40D12R2D7L2D11	OFF-CL40D8R40U8	WDK-L40CU38XL6D8XD30XD8R6XU8	OFF-U30CR40U8L40D8H
---	-----------------	------------------------------	---------------------

STRUCTURE	SKETCH-SF	* STHT	= AREA	RATE	* GRDE	+ HEAT	+ EXWL	* WLHT	= ADJRATE	* AREA	= RPCN	* DEPF	* CNDF	= STR-VALUE
SFR SINGLE FAMILY	1454	1.00	1454	205.36	B	5.00		1.00	210.36	1454	305863	0.80		244690
1 CHIMNEY	0		0						3125.00	0	3125	0.80		2500
1 FIREPLACE	0		0						3125.00	0	3125	0.80		2500
2 BATHS	0		0						9180.00	0	18360	0.80		14688
OFF OPEN FINISHED PORCH	108	1.00	108	124.00				1.00	124.00	108	13392	0.80		10714
WDK WOOD DECK	144	1.00	144	16.25				1.00	16.25	144	2340	0.80		1872
FSP FINISHED SCREEN	110	1.00	110	68.76				1.00	68.76	110	7564	0.80		6051
AFG ATTACHED FINISHED	520	1.00	520	72.00				1.00	72.00	520	37440	0.80		29952
UCP UNFINISHED CARPORT	200	1.00	200	21.25				1.00	21.25	200	4250	0.80		3400

1974 HSF	2536 TSF	RPCN=200.3338/HSF	395459	VALU=160.27/HSF	316367
----------	----------	-------------------	--------	-----------------	--------

<b>STRUCTURE VALUE</b>	<b>316,400</b>
------------------------	----------------

<b>CARD 1 VALUE</b>	<b>441,400</b>
---------------------	----------------

VALUATION	THIS CARD	+ OTHER CARD	= VALUE	PREV-VAL	CHANGE	OTHER CARDS VALUE
LAND	125,000		125,000	62,500	100%	TOTAL VALUE
OTHER FEAT	0		0	0	%	
STRUCTURE	316,400		316,400	164,300	92.57%	
<b>TOTAL</b>	<b>441,400</b>		<b>441,400</b>	<b>226,800</b>	<b>94.62%</b>	

(1034337) Group:0 Clay County, NC	TAX YEAR: 2026 REVAL YEAR: 2026	DEFERRED VALUE	0	NBHD ADJUSTMENT: 1.00 * 441400 = 441,400	APPRaised VALUE	441,400
					TAXABLE VALUE	441,400