

<b>05/18/2026 03:38 OWNERSHIP 2136301</b>	<b>PROPERTY DESCRIPTION</b>	<b>TAX DESCRIPTION</b>	<b>MAP NUMBER</b>	<b>CARD#</b>
SENNEBOGEN JOSEPH J & IDA T  948 HOLLAND RD POWDER SPRINGS, GA 30127 DEED: 00291 0160 8/1/2005 \$250,000	TRACT 2 S W BEND  PLATBOOK/PAGE/DATE: NB: 00174 SWEETWATER BEND SUB 68 COUNTRYSIDE LN	HAYESVILLE HAYESVILLE FIRE DISTRICT	555100061233 RECORD NUMBER: 14437 ROUTE: 555100 228 LISTER: JASON COLLIER 1/1/2026 REVIEWER: JASON COLLIER 11/20/2023	1 / 1

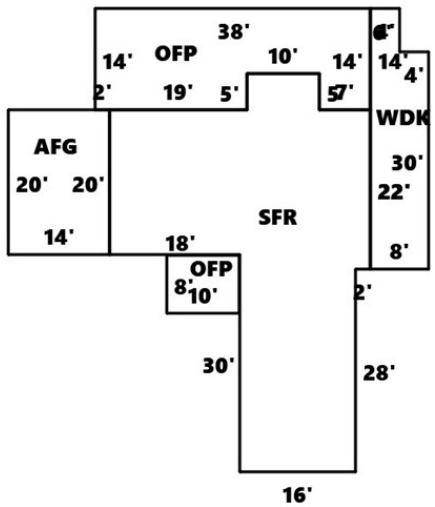

TOPO		STREET		UTILITIES		NOTES				AC
						VIEW				4.0000
#	LAND CLASS	SIZE	BASERATE	* ACF	* ADJ	= ADJ RATE	* UNITS	= LNDVALUE		
1	50RESIDENTIAL	1.000	40000	1.00	1.25	50000	1.000	50000		
2	20OPEN LAND	3.000	10000	1.00	1.00	10000	3.000	30000		
<b>ACREAGE FACTOR:</b>		<b>FRONTAGE FACTOR:</b>		<b>LAND VALUE</b>				<b>80,000</b>		
#	OTHER FEATURES	SIZE	BASERATE	COND	ADJ RATE	UNITS	VALUE			
1	39 S STORAGE-FRAME/CONCRE	1 * 1		0.00		1	0			
<b>OTHER FEATURES VALUE:</b> 0										
FOUNDATION		XTR_FINISH		ROOF TYPE		ROOF MTRL		SIZE/QTY		
5 CONCRETE		09 LOG		02 GABLE		01 ASPHALT		1.0000 STHT 2 BDRM		
WALL FINISH		FLOORS		HEAT&AIR		HEAT FUEL		BUILDING #		
07 LOG		02 TILE 05 CARPET		04 HEAT PUMP 11 CENTRAL AIR CONDI		03 GAS		1		

<b>IMPROVEMENT TYPE:</b>	SINGLE FAMILY	GRADE:	C+10	AYB:	1997	EYB:	2005	CONDITION:	Average	DEPR TABLE:		SQ FT TABLE:	
--------------------------	---------------	--------	------	------	------	------	------	------------	---------	-------------	--	--------------	--

**DIMENSIONS:** SFR=E18S30E16N28E2N22W7N5W10S5W19S20Area:1254;AFG=W14N20E14S20Area:280;OFP=W2N14E38S14W7N5W10S5W19Area:482;WDK=N14E4S6E4S30W8N22Area:264;OFP=W10N8E10S8Area:80;WDK=Area:240;WDK=Area:532;PATIO=Area:482;TotalArea:3614

STRUCTURE	SKETCH-SF	* STHT	= AREA	RATE	* GRDE	+ HEAT	+ EXWL	* WLHT	= ADJRATE	* AREA	= RPCN	* DEPF	* CNDF	= STR-VALUE
SFR SFR SINGLE FAMILY	1254	1.00	1254	161.10	C 1.10	5.50	2.00	1.00	184.71	1254	231626	0.79		182985
2 BATHS	0		0						7398.00	0	14796	0.79		11689
1 HALFBATHS	0		0						3950.00	0	3950	0.79		3121
50%UNF-BSMT	0		627	32.22	1.10				35.44	627	22221	0.79		17555
50%FIN-BSMT	0		627	96.66	1.10	3.30			109.63	627	68738	0.79		54303
OFP OFP OPEN FINISHED	80	1.00	80	100.00	1.10			1.00	110.00	80	8800	0.79		6952
OFP OFP OPEN FINISHED	482	1.00	482	100.00	1.10			1.00	110.00	482	53020	0.79		41886
WDK WDK WOOD DECK	532	1.00	532	13.00	1.10			1.00	14.30	532	7608	0.79		6010
WDK WDK WOOD DECK	240	1.00	240	13.00	1.10			1.00	14.30	240	3432	0.79		2711
WDK WDK WOOD DECK	264	1.00	264	13.00	1.10			1.00	14.30	264	3775	0.79		2982
AFG AFG ATTACHED	280	1.00	280	58.00	1.10			1.00	63.80	280	17864	0.79		14113
PATIO PATIO PATIO	482	1.00	482	3.00	1.10			1.00	3.30	482	1591	0.79		1257

2161 HSF 4868 TSF RPCN=202.4160/HSF 437421 VALU=159.91/HSF 345564

**STRUCTURE VALUE 345,600**

**CARD 1 VALUE 425,600**

VALUATION	THIS CARD	+ OTHER CARD	= VALUE	PREV-VAL	CHANGE	OTHER CARDS VALUE
LAND	80,000		80,000	80,000	%	TOTAL VALUE 425,600
OTHER FEAT	0		0	0	%	
STRUCTURE	345,600		345,600	174,000	98.62%	
<b>TOTAL</b>	<b>425,600</b>		<b>425,600</b>	<b>254,000</b>	<b>67.56%</b>	

**NBHD ADJUSTMENT: 1.00 \* 425600 = 425,600**

<b>(1050034) Group:0</b>	<b>TAX YEAR: 2026</b>	<b>DEFERRED VALUE</b>	<b>0</b>	<b>APPRAISED VALUE</b>	<b>425,600</b>
<b>Clay County, NC</b>	<b>REVAL YEAR: 2026</b>			<b>TAXABLE VALUE</b>	<b>425,600</b>